

Smart-*e*

DESIGN | INNOVATE | ORIGINATE

www.smart-e.co.uk
+44 (0) 1306 628264

Knowledge and experience

Founded in 1999 Smart-e pioneered the transmission of high resolution multi-media audio visual (AV) signals over a single Cat5-8 cable. Since then we have designed and manufactured a wide range of switching and distribution equipment used round the world for over 100,000 AV-based displays. Our products provide professional high performance, content rich AV links between single and multiple source devices to a diverse range of displays. Professionals trust us because we have the technical knowledge and proven experience in the design and manufacture of innovative and reliable solutions that won't let them down, an essential ingredient when the majority of our products form the operating core for any installation



Environment focus

From our initial beginnings we have always had a strong commitment for repairing, reusing or recycling products, packing and components. When designing we understand our responsibilities for making environmentally friendly products. Our main focus is on creating reliable and power efficient products through careful understanding of the requirements and the environment in which they will need to work. Decreasing power consumption not only lowers costs but more importantly reduces heat dissipation which is the main source of component and ultimately product failure. This design ethos and focus gives us the confidence to offer extended warranty periods and a lifetime support to all our Smart-e products



As a trusted producer of high quality equipment with a growing range of AV products, and a reputation for technical innovation, you'll find a Smart-e solution to meet your needs



3 Year Warranty

All products come with a 3 year no nonsense, no cost warranty with optional extension



Lifetime Support

We guarantee to support any Smart-e product we have ever supplied forever



Superior Service

We always go the extra mile to achieve complete customer satisfaction

Contents

MDX	-	Modular, seamless matrix range Available in sizes of 8x8 – 288x288	04 – 05
SDSC	-	Comprehensive 18Gbps AV product range Including matrices, splitters, wall plates & KVM	06 – 07
444K	-	4:4:4 colour sub-sampling product range Including matrices, KVM extenders, splitters	08 – 09
USB	-	USB 2.0 matrix switching and extension Matrix sizes of 8x8, 16x8 & 24x8	10 – 11



Switching Matrices

TX/RX Pairs



MDX-8x8+

A professional flexible Digital Modular Matrix (DMM2) capable of selecting between 8 different devices to 8 displays. Seamless switching together with output video scaling provides a professional image quality, whilst 4-way modular input and output cards cater for a wide range of signal formats

MDX-16x16+

A professional flexible Digital Modular Matrix (DMM2) capable of selecting between 16 different devices to 16 displays. Seamless switching together with output video scaling provides a professional image quality, whilst 4-way modular input and output cards cater for a wide range of signal formats



MDX-36x36+

A professional flexible Digital Modular Matrix (DMM2) capable of selecting between 36 different devices to 36 displays. Seamless switching together with output video scaling provides a professional image quality, whilst 4-way modular input and output cards cater for a wide range of signal formats



MDX-72x72+

A professional flexible Digital Modular Matrix (DMM2) capable of selecting between 72 different devices to 72 displays. Seamless switching together with output video scaling provides a professional image quality, whilst 4-way modular input and output cards cater for a wide range of signal formats



MDX-144x144/288x288+

New to the MDX+ range is the 144x144 and 288x288 chassis size including all the well know and proven features of the MDX+ matrices.



MDX-IP4-HDBT
MDX-OP4-HDBT
4 way HDBaseT transmitter and receiver blade

MDX-IP4-HDMI
MDX-OP4-HDMI
4 way HDMI input and output blade

MDX-IP4-DVI
MDX-OP4-DVI
4 way DVI-D input and output blade

MDX-IP4-VGA
MDX-OP4-VGA
4 way RGBHV input and output blade

MDX-IP4-3GSDI
MDX-OP4-3GSDI
4 way 3G-SDI input and output blade

MDX-IP4-MFB
MDX-OP4-MFB
4 way Fibre input and output blade

Input & output blades

01



02



03



04



05



06



Input & output blades

DIGITAL MODULAR MATRIX²

The MDX range of matrices is an extremely flexible and fully featured modular, seamless switching solution. The range includes a series of chassis sizes aimed at providing the best solution for the installation requirements. Sizes start at 8x8 (8 inputs to 8 outputs) through 16x16, 36x36, 72x72, 144x144 to an impressive 288x288.

The MDX range is ideal for the professional commercial market with its versatility and proven reliability. The matrices are perfect for mission-critical applications running 24/7. Trusted by many Emergency Services worldwide, the units are typically used by the Police, Security, Fire and Rescue and Health Departments in critical operation activities for Command and Control Centres and Disaster Recovery Vehicles.



Every matrix can accept multiple input and output blades providing a variety of video, audio and control functions. Each blade has four channels accommodating a wide range of signal types, including 4K, 2K and 1080p video resolutions presented as HDMI, HDBaseT, DVI-D, VGA, Fibre and 3G-SDI.

Individual output scaling for both HDMI and HDBaseT produces correct aspect ratio for any display size. Multiple control options are included within each chassis as standard for RS232, IR and IP, with an internal Web Browser for channel selection and configuration.

Smart-e

+44 (0) 1306 628264
www.smart-e.co.uk

DESIGN | INNOVATE | ORIGINATE

SDSC

The SDSC product range supports the switching and distribution of 18Gbps HDMI video. This includes video resolutions up to 4K and 2K with a refresh rate of 60Hz, together with colour sub-sampling of 4:4:4 for YPrPb, totaling 18Gbps and HDCP 2.2 compliant

The SDSC range provides the ideal solution to the challenge of distributing high resolution video and audio signals throughout a building. Crystal clear images and hi-fidelity sound can now be transmitted throughout an installation using only a single piece of network cable to each display. Distances of up to 150m can be achieved in a single run, making the unit ideal for large development wide-distribution

The SDSC range conforms to the latest 18Gbps signal specification making this solution ideal for the latest visual HDR formats.. Whilst 18Gbps signals are available on the HDMI outputs, Digital Stream Compression is used on each Cat 6/6A transmission providing visually lossless compression.



- 01 **SDSC-2001**
70m extender for HDMI and USB-C DP video, charging port and USB 2.0
- 02 **SDSC-2002**
70m extender for HDMI and DP video with USB 2.0 and local loop i/p

Smart-e

+44 (0) 1306 628264
www.smart-e.co.uk

Switching Matrices



18 Gbps
4K/60Hz
HDR10
4:4:4



Wall plate extenders

03 **SDSC-1050**
50m extender for HDMI and USB-C DP video, USB-C charging and POC

04 **SDSC-1051**
50m extender for HDMI and DisplayPort video and POC. Auto switching

SDSC-4x4-RSP & SDSC-8x8-RSP

The SDSC-4x4 and SDSC-8x8 are both fully featured matrix switchers that support the transmission of 18Gbps HDMI video (up to 4K/2K@60Hz 4:4:4, 18Gbps, HDCP 2.2) and multi-channel digital audio from 8 HDMI 2.0 sources to 8 HDBaseT™ outputs, all with mirrored HDMI outputs

Extenders

150m

SDSC-925

The SDSC-925 is an 18Gbps HDMI extender for extra long range cable applications capable of reaching lengths of up to 150m. With RS232 and IR extension makes this a professional product ideal for Commercial, Education and Corporate installations

SDSC-3100 & 3101

The SDSC-3100 and 3101 are 18Gbps HDMI extenders for 100m and 70m cable applications respectively. RS232, IR, S/PDif and LAN (SDSC-3100) extensions makes this a fully featured professional product together with the ARC return audio channel ideal for Residential use



Cat 6/6A Splitter

SDSC-1150-BUN

1 in and 4 out HDBaseT splitter able to transmit 1080p/4K UHD signal over 150/120m of Cat 6/6A cabling to 4 remote displays. Added features include RS232 and IR pass-through together with HDMI looping input and local de-embedded audio

SDSC-3000 & 3001

The SDSC-3000 and 3001 are flexible and cost-effective KVM extenders for HDMI, USB 2.0, bi-directional IR, full duplex RS232 and 100BaseT Ethernet together with Power Over Cable (POC). Capable of USB data rate up to 480Mbps ideal for multiple peripherals



DESIGN | INNOVATE | ORIGINATE

44^k

The 44K product range supports the switching and distribution of uncompressed 18Gbps HDMI video. The products are compatible with video resolutions up to 4K, including 2K and 1080p with a frame rate of 60Hz, together with colour sub-sampling of 4:4:4 for YPrPb totaling 18Gbps and HDCP 2.2 compliant

The 44K range is a comprehensive mix of products aimed at the field of signal distribution and conversion.. High quality UHD images and hi-fidelity sound can now be transmitted throughout an installation using only a single piece of network cable to each display. Distances of up to 100m can be achieved in a single run, making the unit ideal for large development-wide distribution

The 44K range conforms to the latest 18Gbps signal specification making this solution ideal for the latest visual HDR formats



Extenders

444K-750

70m

70m transmitter/receiver pair for 18Gbps 4K HDMI, IR, RS232 & POC



444K-875

100m

100m transmitter/receiver pair for 18Gbps 4K HDMI, IR, RS232 & POC



444K-912

70m

70m wall plate TX/RX pair for 18Gbps 4K HDMI, IR, RS232 & POC



Smart-e

+44 (0) 1306 628264
www.smart-e.co.uk

Switching Matrix



444K-8x8-L/F

The 444K-8x8-L HDBaseT™ is a 8x8 matrix switcher that supports the transmission of HDMI video (up to 4K/2K@60Hz 4:4:4, 18Gbps, HDCP 2.2) and multi-channel digital audio from 8 HDMI 2.0 sources to 8 HDBaseT™ outputs, all with mirrored HDMI outputs

Cat 6/6A Splitters

444K-TX660



The 444K-TX660 is a 1 in and 4 out HDBaseT splitter with RS232 passthrough and HDMI looping input, capable of transmitting 4K UHD signal over 70m

444K-985-USB



The 444K-985-USB is a flexible and cost effective KVM extender for HDMI, USB 2.0, bi-directional IR, full duplex RS232 together with Power Over Cable (POC).

44K

444K-TX960



The 444K-TX960 is a 1 in and 4 out HDBaseT splitter with RS232 passthrough and HDMI looping input, capable of transmitting 4K UHD signal over 100m



444K-2500

The 444K-2500 is a highly integrated compact video processor capable of multiple functions. The unit can be used as a 4x4 seamless switching and scaling matrix, 2x2 video wall processor and has the added ability to act as a quad-split PIP/POP processor with multiple user selectable layout options.

Switching Matrices

USB-8x8

The USB-8x8 is a USB matrix and extender with CAT 6/6A outputs. The unit allows the selection and transmission of up to 8 different computers to up to 8 peripherals e.g. Touchscreen, Mouse and Keyboard. The peripherals can be located at distances of up to 50m of Cat 6/6A STP cable with the appropriate receiver USB-RX100



USB-16x8



The USB-16x8 is a USB matrix and extender with CAT 6/6A outputs. The unit allows the selection and transmission of up to 16 different computers to up to 8 peripherals e.g. Touch screen, Mouse and Keyboard. The peripherals can be located at distances of up to 50m of Cat 6/6A STP cable with the appropriate receiver USB-RX100

USB-24x8

The USB-24x8 is a USB matrix and extender with CAT 6/6A outputs. The unit allows the selection and transmission of up to 24 different computers to up to 8 peripherals e.g. Touchscreen, Mouse and Keyboard. The peripherals can be located at distances of up to 50m of Cat 6/6A STP cable with the appropriate receiver USB-RX100



USB-Plus

The USB-Plus is an enhanced USB matrix and extender with CAT 6/6A outputs. The unit allows the selection and transmission of up to 24 different computers to up to 8 peripherals e.g. Touchscreens, Mouse and Keyboard and Web cams. USB 2.0 together with Ethernet 100BaseT signals can be extended up to 100m of Cat 6/6A STP cable and recovered using the appropriate receiver USB-RX100-Plus

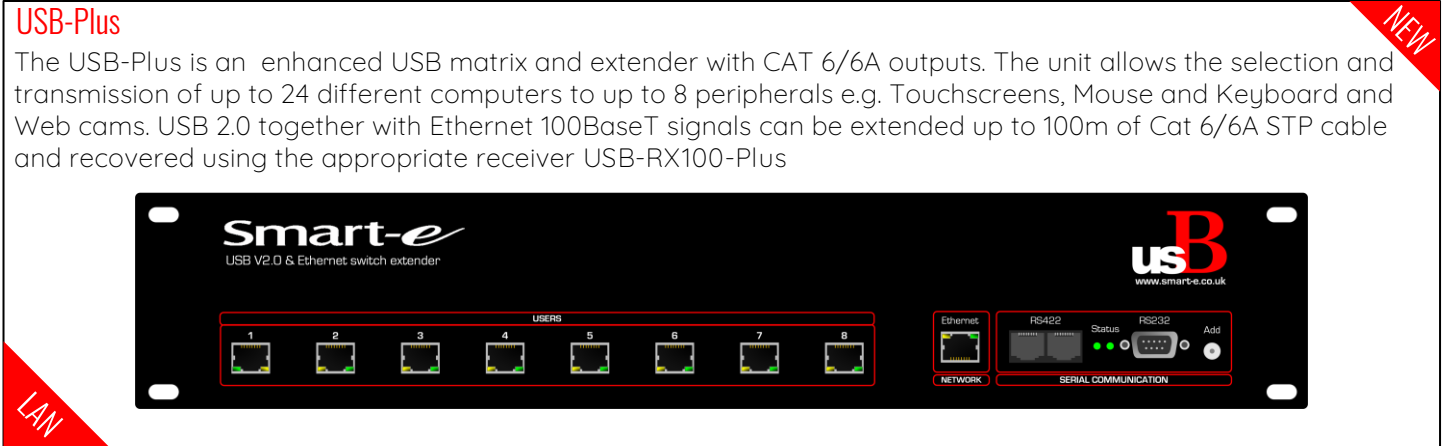

Extenders

USB-CTL

100m rotary control panel for individual USB matrix series user control, POC



USB-RX100

50m Cat6/6A STP wall plate receiver with integral 4 port USB HUB with remote power



USB-RX100-Plus

100m Cat6/6A STP wall plate receiver with integral 4 port USB HUB and Ethernet, POC

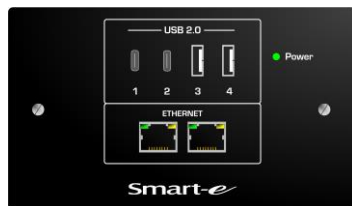

USB matrix switching and extension is a vital part of a complete interactive user experience. Computers can be easily and immediately selected to different collections of peripherals all at remote locations from the PCs. The PCs normally being co-located in a well maintained, air-conditioned secure communications room

The Smart-e USB range includes chassis sizes of 8x8 (8 PCs to 8 Users) through to 24 x 8 (24 PCs to 8 Users). USB 2.0 signals up to 300Mbps can be switched and extended to distances of 100m of Cat 6/6A STP

The USB solution consists of a switch matrix and individual receivers connected to the end of the cable run. The receivers are configured as wall plate for installation into standard UK double sized back pattrness boxes. The receiver also has an integral 4-port USB hub allowing up to 4 different peripherals to be connected

Control is via RS422 serial or individual panels located at the remote end point.

USB
www.smart-e.co.uk



Smart-e

+44 (0) 1306 628264
www.smart-e.co.uk

Diverse applications

Smart-e systems run demanding, mission-critical applications for many command centres around the UK, and as specified designers and manufacturers of equipment for many of the world's top banks, our products are relied upon to run building-wide, multi-format video distribution systems. The use of a single cable combined with compact product design, and the flexibility of multi-functional features, offers professionals a wide range of AV solutions in different environments, including:

Corporate Communications	Command & Control	Presentation Solutions	Interactive learning
			
			
Digital Signage	Super Yachts	Custom Installations	Health & Wellbeing



Products conceived
and designed in the UK

@SmarteAV



Smart-e

www.smart-e.co.uk
+44 (0) 1306 628264